



ARRL Periodicals Archive – Search Results

A membership benefit of ARRL and the ARRL Technical Information Service

ARRL Members: You may print a copy for personal use. Any other use of the information requires permission (see Copyright/Reprint Notice below).

Need a higher quality reprint or scan? Some of the scans contained within the periodical archive were produced with older imaging technology. If you require a higher quality reprint or scan, please contact the ARRL Technical Information Service for assistance. Photocopies are \$3 for ARRL members, \$5 for nonmembers. For members, TIS can send the photocopies immediately and include an invoice. Nonmembers must prepay. Details are available at www.arrl.org/tis or email photocopy@arrl.org.

QST on CD-ROM: Annual CD-ROMs are available for recent publication years. For details and ordering information, visit www.arrl.org/qst.

Non-Members: Get access to the ARRL Periodicals Archive when you join ARRL today at www.arrl.org/join. For a complete list of membership benefits, visit www.arrl.org/benefits.

Copyright/Reprint Notice

In general, all ARRL content is copyrighted. ARRL articles, pages, or documents--printed and online--are not in the public domain. Therefore, they may not be freely distributed or copied. Additionally, no part of this document may be copied, sold to third parties, or otherwise commercially exploited without the explicit prior written consent of ARRL. You cannot post this document to a Web site or otherwise distribute it to others through any electronic medium.

For permission to quote or reprint material from ARRL, send a request including the issue date, a description of the material requested, and a description of where you intend to use the reprinted material to the ARRL Editorial & Production Department: permission@arrl.org.

QST Issue: Feb 1922

Title: Official Report on the Second Transatlantic Tests

Author: Paul F. Godley

[Click Here to Report a Problem with this File](#)

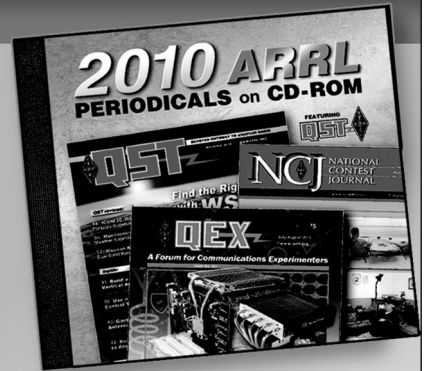

2010 ARRL Periodicals on CD-ROM

ARRL's popular journals are available on a compact, fully-searchable CD-ROM. Every word and photo published throughout 2010 is included!

- **QST** The official membership journal of ARRL
- **NCJ** National Contest Journal
- **QEX** Forum for Communications Experimenters

SEARCH the full text of every article by entering titles, call signs, names—almost any word. **SEE** every word, photo (including color images), drawing and table in technical and general-interest features, columns and product reviews, plus all advertisements. **PRINT** what you see, or copy it into other applications.

System Requirements: Microsoft Windows™ and Macintosh systems, using the industry standard Adobe® Acrobat® Reader® software. The Acrobat Reader is a free download at www.adobe.com.

2010 ARRL Periodicals on CD-ROM

ARRL Order No. 2001

Only \$24.95*

*plus shipping and handling

Additional sets available:

2009 Ed., ARRL Order No. 1486, \$24.95
 2008 Ed., ARRL Order No. 9406, \$24.95
 2007 Ed., ARRL Order No. 1204, \$19.95
 2006 Ed., ARRL Order No. 9841, \$19.95
 2005 Ed., ARRL Order No. 9574, \$19.95
 2004 Ed., ARRL Order No. 9396, \$19.95
 2003 Ed., ARRL Order No. 9124, \$19.95
 2002 Ed., ARRL Order No. 8802, \$19.95
 2001 Ed., ARRL Order No. 8632, \$19.95



ARRL The national association for AMATEUR RADIO™

SHOP DIRECT or call for a dealer near you.
 ONLINE WWW.ARRL.ORG/SHOP
 ORDER TOLL-FREE 888/277-5289 (US)

at the old set on a cold winter's night, the bulbs burning cosily in front while the generator purrs sweetly in the corner, the old cob pipes neatly filled in advance and set in a row for a hard night's work—and then clear England, Scotland, France, and Holland in turn! (No, we never take a

drop of stuff like that, and we really believe that such things some day will come to pass.)

Surely radio has been given added impetus by these tests, and certainly the day of International Private Radio has been brought closer!

Official Report on the Second Transatlantic Tests

By Paul F. Godley

MENTAL processes during great moments are extremely complex and I shall never be able to fully recount those of mine, either upon the memorable occasion when, amidst the inspiring farewells of a host of renowned amateurs, the "Aquitania" bore me towards an unknown professional fate, or those of that other and greater moment, when without regard for the atrocities of the Scottish night the first American amateur signal finished its 3,500 mile journey at Ardrossan.

On the first occasion I was overwhelmed with a wish that some fairy power might sweep twenty thousand "hams" to a place beside me, while on the second it was with the utmost difficulty that I restrained a joy which cried for the slam of a switch, the mad whine of a motor, and the crazy stuttering of a key. No sinking tramp at sea ever bewailed its lack more than I bewailed it then.

The "Aquitania's" sailing marked the beginning of a short respite from a physical strain under which work, plan and preparation had placed me. No one else will ever know how much I needed sleep, and I began taking it in large doses. On the other hand, the first signal brought with it welcome and almost complete mental relief, for five nights of listening to static and high power station harmonics near London had left me in a somewhat dubious frame of mind, which may be judged from the fact that all thoughts of sight-seeing were dropped forthwith—a trip to Paris which had been planned was given up, and I began to muster meteorological "dope" from every quarter.

The first signal also ushered in a new period of physical strain, for it was found necessary to set up equipment under an indifferent tent, in an open field near the beach, and the test period was attended throughout by high, gusty, changing winds, heavy downpours, and a chill damp which drew heavily on one's reserve energies. So far as I know, for an American, there

is but one comfortable place in winter in all the British Isles. That place is in bed—with a hot water bottle at your feet. Hospitality, of which I found a plenty everywhere, will warm the cockles of your heart, but it's no good for the joints, so those whose hospitality I sampled secretly complained of gas bills.

It seems to me now that the most remarkable phase of the entire undertaking lay not so much in its complete success but rather in the thoroughly whole-hearted co-operation encountered at every step—both during the formation of plans and during their execution—and before following through this narrative every American relay man will be glad to recognize a debt of gratitude towards all those men and those organizations who seemed to find *pleasure* in doing *anything* to insure success.

It was generally known that various American manufacturers had lent their full support to the project. Sensitive, rugged Baldwin 'phones did their excellent bit. None in England could equal their ruggedness, and none were more sensitive. The small precision wave-meter of the General Radio Company checked to a hair on 200 meters with the unusually fine standard owned by Mr. Frank Phillips, of Wembly Park, London. Burgess batteries took to the wet and muck without a whimper. The A. P. amplifier tubes I had used in tests on this side were still intact and carried on throughout the whole procedure. The Radio Corporation's U.V.200 detectors functioned as gas content tubes in a way which was surprising to British amateurs who saw them working, while the Paragon Super-heterodyne and regenerative receivers pulled in signals in a manner which astounded everyone including Inspector D. E. Pearson, of the Marconi Marine Communication Company, Ltd., who was checking operator throughout the test.

During formation of plans, encouragement was offered by a full score of prominent radio engineers, and everyone was

delighted with the generous attitude displayed by W. A. Winterbottom, Traffic Manager, Radio Corporation of America, whose efforts made possible the daily reports via Carnarvon and New Brunswick—reports which passed as paid messages but which were never paid for, because Mr. Otto Rochs, Marconi's (England) able traffic manager, informed me there had been no intention of accepting payment. Messrs. Allen and Bradfield, Marconi's joint general managers, took a fatherly interest in the whole program. No amateur could wish for better friends, and the very busy men they found time to be lavish with suggestion, assistance and real hospitality. Their assistance took the form of men and

In England Mr. P. R. Coursey, editor of "Wireless World," and his associates labored cheerfully to properly organize England, and Commander Frank Phillips opened his home and placed his very complete station at my disposal, while all manufacturers did their share toward boosting the interest in the tests in England by offering prizes.

I wish also to express my thanks for the assistance unwittingly given by one Mr. Louis Falconi, station 5ZA, of Roswell, New Mexico. It will probably be a great surprise to him when he learns that covering a period of about one week prior to my sailing, during which time the apparatus which I was to use was under test,

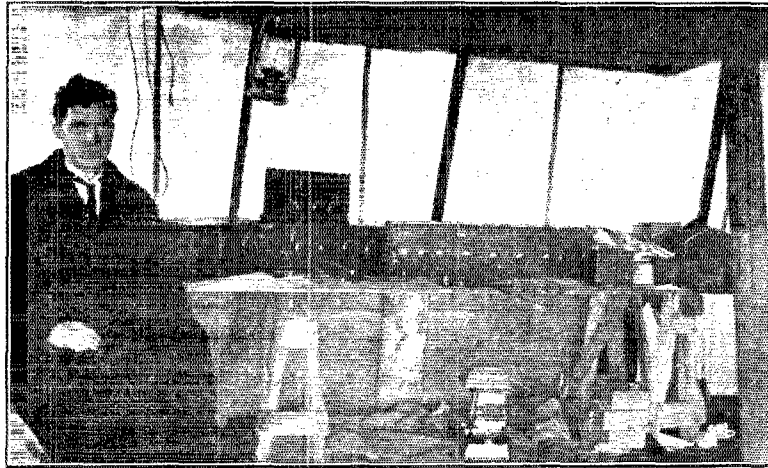

Inside the tent at Ardrossan—Mr. Pearson, checking operator.

materials at Glasgow, and the services of Mr. Pearson at Ardrossan. Capt. H. J. Round, of the same company, and whose valued contributions to the art are quite familiar to all American amateurs was also greatly interested in it all and offered anything he had in the way of equipment, such as a 22-stage amplifier, and proved an exceptionally fine host during my visit to the Chelmsford works of Marconi Co.

Of course, amateurs both in America and England were always ready with assistance. We dared to expect that, but certain amateur services stand out a bit from the rest. On this side it seems to me considerable credit should go to E. H. Armstrong for the keen interest he displayed prior to the tests, and the amount of time and energy which he expended in an effort to insure the success of this great undertaking. I feel that I should also call attention to the generosity displayed by the Adams-Morgan Company in releasing the writer's services for this work at a season, when, as all radio manufacturers know, every effort counts.

I used his very uniform signals to check and recheck the operation of the equipment. I not only received his signals during this period on the regenerative receiver, using the detector and two-stage amplifier, but also was able to get him nicely on a nine-turn loop in conjunction with a super-heterodyne receiver, when his signals were of such strength and regularity as to enable the operation of a four-ohm sounder by the insertion of relays in the circuit. The results of this reception greatly surprised several members of the Radio Association of Northern New Jersey, who chanced to visit my home very early one morning.

A thing which stands out in great prominence is this: the American amateur has given his British cousin a surprise. I am quite certain there wasn't an amateur in all Britain who thought it could be done. I can well imagine the glad surprise which must have spread out from London, when it became known that signals *were* being received. British men came in on it too, and as a result of all these signals from

America, there is a good deal of speculation in Britain at this moment on the endless possibilities of amateur radio on short waves. Whereas in the past they have been thinking in terms of 1,000 meters, they are now thinking in terms of 180 meters. They are limited to ten watts input, and their antennas must have no more than 160 feet of wire total.

Wasteful coils are necessary to load such a small antenna to 1,000 meters. Also, waves of this length do not travel at night like the shorter ones. Many will listen for us on 200 meters, and I hope soon we may be receiving *them* on 180. Good engineering on their part and a bit of luck will make it possible even with ten watts.

Good fortune seems to have followed everywhere. To begin with, there was that very impressive dinner the night preceding my departure, and the farewell party at the dock. An account of these doings has already been printed, but a part which was not staged was that I should meet on the deck of the "Aquitania" as she left New York Harbor, one H. H. Beverage, receiving engineer of the Radio Corporation of America, and by the way one who qualifies as being a "hard boiled ham." Needless to say, I had not been with Beverage long before we got around to that thing which is nearest his heart, to wit, the Beverage wire, as a static reducer.

Now, to those of you who are uninitiated an explanation of this term "Beverage Wire" will be necessary and it will be forthcoming later. The point I want to bring out here is that the thought of this Beverage wire served as a great buoy during the period previously mentioned when, after listening five consecutive nights near London, I had heard nothing but static and harmonics.

Before the "Aquitania" had been away many hours the great interest displayed in the undertaking began to be manifested by the radiograms sent by many amateur and professional radio men. The first of these came in over the signature of J. Andrew White, editor of "Wireless Age" and read:

Just an added slap on the back old man to emphasize my sincerest wish that this trip of yours will go down in radio history.

This was followed by several others among which was a greatly appreciated one from my old friend Harry Sadenwater, who, it will be remembered, served as radio officer on the ill-fated NC-3 during the transatlantic seaplane flights. He heartily wished me a "bon voyage and wonderful success."

Late in the evening of the first day I learned that Mr. H. M. Short, Superintendent, Marconi Int'l. Marine Communication Co., Ltd., had requested the Aquitania's

radio men to extend all courtesy to me and they proceeded to do all possible in making me feel at home, with the result that twenty-four hours later I found myself taking the following from WBF:

From Hartford, Conn.

*To Paul F. Godley, SS Aquitania via WBF.
Bon Voyage! The entire radio world is pulling for you!*

(Signed) Warmaxnell

while on the fourth day (Saturday) the High School Radio Club of Montclair, N. J. passed out a "73" via VCE (Cape Race).

Contrary to what may have been the general idea of this trip, at no time had I viewed it as anything even remotely resembling a lark, for there were sacrifices which had to be made. But, it was these radiograms—each bubbling over with sincerity and a *will* for success which first brought home to me the extent to which all these eyes reddened by long watches on the relay routes must be following me. As I tossed about in bed during the wee hours of Sunday morning the 19th of November I took note, too, of the veiled interest which had been shown in engineering circles, and before dropping away to sleep I remember mentally repeating over and over the resolve to *get signals or bust!*

The voyage was not rough—neither was it particularly smooth. Fortunately the state of the sea concerned me not at all. A good portion of my time was spent with the three very likable men in the radio cabin, Messrs. Maudesley, Farnam and Porter, respectively Chief, 2nd and 3d operators. It was impossible to do any real listening on amateur waves however. The vast quantities of radio traffic and book work which is to be found on the ocean greyhounds make this impossible, and I had, for the most part, to imagine the "bon voyages" and "73s" and "good luck" messages which were being passed out on short wave lengths, and I understand there were many of them.

As we neared the French coast I filed a message to a staunch League member, Mr. Leon Deloy, of Nice, France, extending greeting on behalf of his American contemporaries to which he promptly replied: "Radio greatly appreciated wish you complete success would be delighted to meet you".

I was very much surprised upon reaching the dock in Southampton to find Mr. H. J. Tattersall, Superintendent of the Marconi Company in Southampton, waiting to help me through the customs, and I was indeed glad to have him. It happens that a very heavy duty had just been placed on all radio equipment. Under these circumstances, British custom officials were inclined towards placing all of my apparatus in the warehouse in order that within the next two to four weeks some customs

officer might go over it at his leisure, place a proper valuation upon it, and exact duty accordingly. After considerable running around to various officials, and after a great deal of pleading with the Chief Customs officer of that port, we were told that if I cared to leave \$100 with the customs people, they would pass the equipment through, the \$100 to be returned at that time when the equipment was again taken from the country.

And so I finally reached London on a funny little train, and began to meet the various notables in and around London. I consider it of extreme fortune that it was possible for me to attend a meeting of the Wireless Society of London, and latter to hear an extremely interesting lecture by

met Marconi. He showed a flattering interest in a recital of the events which had led up to my visit and in amateur accomplishments in the States. He expressed every hope and seemed to feel confident that the tests would prove successful, and as I left him he asked me to pass on to American amateurs his good wishes, for, he said: "I, too, am but an amateur!"

As we passed out of the old building which had housed the Royal Society of Arts for many decades, I again felt myself being steered, and again we approached a long table in the balcony of a gaily colored restaurant. This, apparently, was to be a little dinner party in my honor, and so it proved—and it was a merry, long-to-be-remembered time we had while I managed

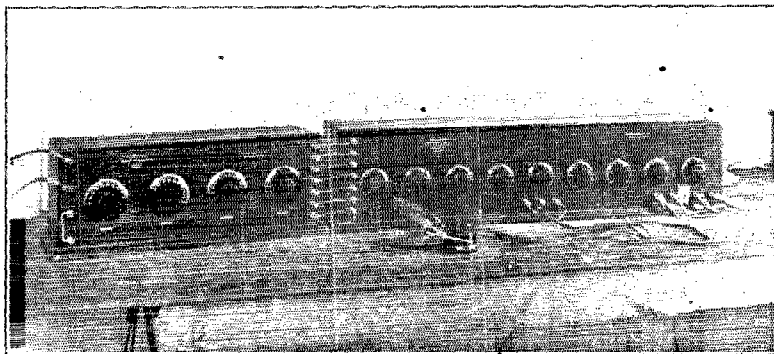

The tuner and amplifier which made up the Super-Heterodyne used at Ardrossan. As connected for use with Beverage antenna, the special regenerator shown on page 25 was inserted between this tuner and the antenna.

Dr. Fleming at a meeting of the Royal Society of Arts, and to meet and chat with such men as Senatore Marconi; Admiral Sir Henry Jackson, president-elect of the Wireless Society of London; Mr. Campbell-Swinton, past president of the society; Prof. E. W. O. Howe; Mr. E. K. Shaughnessy of the Wireless Section of the G. P. O.; Mr. F. Hope-Jones, Chairman of the Wireless Society of London, and many others.

Just prior to the meeting of the Wireless Society I was led into a large room adjoining the lecture hall and to my surprise found a long table heavily laden with various attractive things to eat and behind which several young ladies were wielding the tea things. It was time for a regular meal, so my stomach said, but it didn't quite look like a regular meal. However, after being assured that it was safe to do so I managed to personally superintend the rapid movement of a considerable portion of the commissary, notwithstanding that most everyone made great efforts to get me to talk.

At the close of Dr. Fleming's lecture I

to put away another big feed all in the same evening. And would you believe it—there were two "O.W's" in the gang! and they, too, joined in the toast to American Amateur Radio and to the success of the Transatlantic tests

As far as I was concerned, British hospitality had never been properly advertised. I had never expected so great an effort to make me feel at home, and while I was thinking this all over I was at the same time noting the glances on every hand which I understood as meaning that these British amateurs had been unable to decide whether I was just a "nut" or whether I was really confident of our ability to put the thing over.

Preliminary arrangements for an operating permit had already been made by Coursey and two days after arriving in London I set up the regenerative receiver and super-heterodyne at the station of Commander Frank Phillips above mentioned. British amateurs are very keen on radio-frequency amplification. Remember, most of their work is done on 1000 meters which

makes it a somewhat simpler matter. Phillips, the designer of the "Burndept III" receiver, thinks very highly of his fine little outfit. Before many hours, however, he agreed that the Paragon regenerative combination gave signals somewhat better than those obtainable on the outfit he was using, and that it was a thing not to be lightly passed by.

The vast numbers of harmonics from single circuit tube transmitters and Poulson arcs, which one picked up at all times, struck me forcibly. Atmospheric conditions, too, were of an unusual type. I have never before encountered anything like it. During the winter time here in America we expect atmospherics will be negligible, or, if present at all, quite uniform in their habits. At Wembley Park I found them suddenly increasing during certain short periods of the night, and suddenly decreasing to appear again in another quarter, and in a new form.

Later, we got the Super-Heterodyne going, and it was quite apparent that all who saw it in operation were greatly impressed. Cmdr. Phillips showed particular delight when we picked up a 10-watt radio phone station at a distance of 18 miles on a coil having 8 or 10 turns and a diameter of 3 inches. We revolved the coil about on a pivot, and in this manner got the direction of the transmitting station. During our work with the super-heterodyne, I decided to make alterations in the mechanics of the capacitive feed-back. Accordingly, I put a bushing through the panel, placed a shaft in the bushing with a spring washer

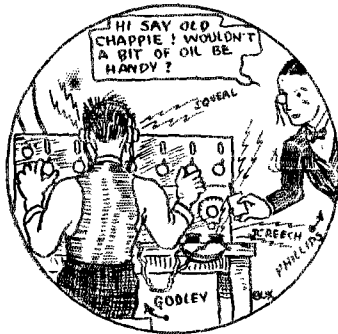

to hold it firm, and so arranged this shaft that it controlled the small condenser. During the initial test of this little device the amplifier began to squeal vigorously. Phillips immediately jumped up from his chair and rushed to another room, to appear a few minutes later with an oil can from his wife's sewing machine, whereupon he proceeded to oil this shaft in its bearing. He maintains that there is no connection between the squeal of the amplifier

and the idea which he got that oil was needed, and it may be that he is right; nevertheless, it is too good to keep.

London newspapers began to show a considerable interest in the tests very shortly after my arrival, and I was greatly amused to find the following printed on the editorial page of the "London Star" on November 30th:

THE FAR CALL

Prospects of the New Trans-Atlantic Wireless Test.
By "Nautacore."

"On December 8 there begins a series of Transatlantic wireless tests similar to those which took place last February. As then, American amateurs, using small power and short wave-lengths, will try to get into communication with this country.

"The stations taking part are purely "amateur" but must be proved capable of bridging at least 1,000 miles in the States or Canada. With an amateur's small power, and short and theoretically inefficient wave-length, 1,000 miles is a big achievement; yet it has been done. In theory, a station can do little without a fair amount of power behind it, but, in fact, American stations, with a nominal maximum range of 250 miles, are often plainly heard in this country, whilst Valentia (west coast of Ireland) has kept up a brisk correspondence with British ships entering New York Harbour, although the official lists state that she cannot exceed 600 miles.

"Last February's tests were unsatisfactory from the point of view on both sides. In the States too many persons "tried their hands." On this side, the delicate, finely-tuned instruments employed were interfered with by wireless novices using receivers which acted as miniature transmitters—drowning the feeble pulsations of American aeriols. Americans, however, reject that excuse for our non-reception, declaring that incompetence had a lot to do with it; and to make certain of really good reception this time they are sending over one of their hardest of "hard-boiled hams" with a brand-new bag o'tricks and their good wishes. He will show us how it should be done.

"The wireless magazines have made their last appeal to those not taking part in the contest to "earth" their aeriols and go out for a walk during the specified hours and nights, so that interference may be reduced to a minimum. Those who have entered their names will conscientiously avoid "regeneration." Will all respect to the "hard-boiled ham" I invite him to do likewise—avoid "regeneration." Then we all might get something."

(And now you know why I went to Scotland!!)

I was most anxious during all this period to gather what information I could concerning the handicaps under which British amateurs were working. The situation is something like this. Prior to the war British amateurs were allowed wave lengths of 180 meters and were limited to an input of but ten watts, licenses to use transmitters being granted only in a few cases. Subsequent to the war, due to some processes in the British Post Office which I was unable to analyze, British amateurs were given a choice between an operating wave length of 180 and 1,000 meters. There was a time during pre-war days when we ourselves no doubt would have welcomed operation on 1,000 meters, and it is I presume only natural that British amateurs availed themselves of this opportunity to choose the longer of the two. In view

of what we have learned concerning the efficiency of antennas, and in view of the fact that the total length of wire in their antennas must be less than 160 feet, however, it is quite apparent that any transmitters operated by amateurs on a wave length of 1,000 meters would be operating at a very low efficiency. Further, our experience with short wave transmission has taught us that we may expect phenomenal distances under night-time conditions, particularly during the winter.

I believe that as the result of these tests, and as the result of some discussion during my visit to England concerning the relative merits of the two wave lengths, British amateurs are now studying the

time I suggested to him that amateurs could cause very little disturbance, even if given the greatest of freedom, provided they were kept to 180 meters. His reply was to the effect that the shorter the wave length the greater the number of stations there were which could be operated within a narrow band, at the same time overlooking the fact, apparently, that all waves below 275 meters are at present almost completely blanketed by harmonics from various high power spark, arc, and tube transmitters; and, in this connection, I was highly amused a day or so later to be able to count up to the 39th harmonic radiated by a G. P. O. station which is located in the north of Scotland. This station is trans-

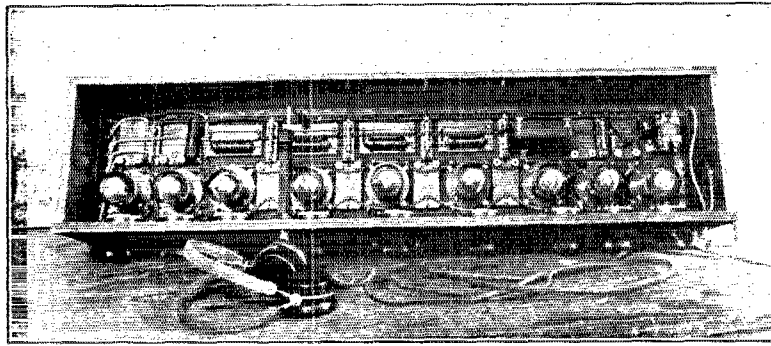

Interior arrangement of amplifier cabinet of Super-Heterodyne used at Ardrossan.

possibilities in connection with transmission on 180 meters, and in fact men repeatedly asked me for such pointers as it was possible for me to give them regarding transmission on short waves.

As mentioned previously, I met Mr. E. H. Shaughnessy, chief engineer, wireless section, G. P. O., and got, in an offhand manner, some of his views concerning amateurs and amateur work. Briefly, I should say that if Mr. Shaughnessy's attitude is representative of that of the G. P. O., British amateurs have a hilly road ahead of them. Mr. Shaughnessy showed great interest in amateur development in America—in fact, he seemed greatly surprised by the rapid strides which have been made in connection with radio-phone broadcasting since the war; but expressed the opinion that whereas American amateurs were so fortunate as to be situated on a large continent, set apart by itself, British amateurs found themselves on a small island, close to many foreign lands, with the result that no liberties could be given them without first considering what effect these liberties might have on various international radio communication problems. At this

mitting a great portion of every day.

It is most reasonable to assume that British as well as American men are able, eventually to get that thing which they go after, and there is no doubt in my mind that British amateurs are going after a more liberal G. P. O. policy. Neither can I believe that the British public can long remain blind to the almost limitless possibilities and advantages to be derived from a liberal radio-phone broadcasting program. I wonder if even here in America we amateurs realize that today the state of the art makes it possible for the President of these United States to speak directly to every citizen in the land? One's imagination cannot help but see the immense value of such an arrangement during times of national peril.

During the entire first week in London everything was blanketed with heavy fog. On one morning in particular upon coming from the "Underground" onto the Strand, the fog and smoke was so thick that it was impossible to see more than twenty feet ahead. Accidents of all sorts were occurring in the streets, and finally traffic had to be entirely abandoned, notwithstanding

the fact that at all main street intersections huge flares were going continuously. At this time the fumes in the atmosphere were so violent as to make one cough continually, and the tears run down one's cheek.

Five nights of this sort of thing were quite enough. I was not at all at home under circumstances such as these, and since I could get no assurances from anyone that these conditions were not to continue indefinitely, I came to the fixed conclusion that the vicinity of London—even southern England for that matter—was no place for me, and arranged accordingly to proceed to Scotland, having previously chosen Ardrossan as the location providing conditions near London did not warrant remaining there.

Immediately my decision to change locations became known, wild tales of all sorts began to come to me, concerning the terrible Scotch climate—the rains, the mists, the chill temperatures, to say nothing of the ill effects of the Scotch whisky which one would most certainly be unable to dodge. Even taking all of this with a good grain of salt, I was not sure that I looked forward to the trip into the "Scotch wilds" with any particular pleasure, particularly in view of the fact that even after having been in England a week, I cannot remember at this time of having found a sufficiently warm spot.

The first problem which presented itself subsequent to this decision was the necessity for procuring an extension of the operating permit, or in lieu of that, a new permit which would allow the operation at Ardrossan. Messrs. Coursey, et al., were not at all enthusiastic concerning the possibilities of such extension within the few hours available, and were unable to see by what process such an extension could be pried out of the G.P.O. Several efforts were made to put me in touch with Capt. D. Loring of the G.P.O., and they failed, and finally deciding that we must have action, I myself went to the General Post Office Building, and by good fortune obtained an interview with Mr. J. W. Wissenden, Assistant Secretary, who proved to be a very good listener and a very amiable gentleman, but who was unable for some little time to see just how he could comply with my request. After an interview lasting about thirty minutes, he proved himself to be a thoroughly good fellow, and assured me that the required permit would reach Glasgow the first of the following week—in time to enable me to institute the program as scheduled. I remember telling him, after he had announced his decision, something to the effect that "I could expect no more from my own father", and I still feel that way about it. I do not know what sort of magic wand Mr. Wissenden waves, but I do feel sure

that he is apt to prove a real friend to British amateurs in the not too distant future. Coursey and the other men in his office at the time seemed greatly surprised to find me back so quickly with the good word, and someone remarked something to the effect that it must be great to be an American. I wonder what he meant?

The permit reached me in good time, via Coursey, and here it is:

184562-21 GENERAL POST OFFICE,
LONDON, E. C. 1.
2 December, 1921.

Mr. C. F. Phillips is hereby authorized to install and use for receiving wireless signals for experimental purposes during the month of December, 1921, at a station within 40 miles on land of Glasgow (but not within 1 mile of any Government Wireless Telegraph Station), apparatus for that purpose (including valves), and any aerial which may be considered necessary for the experiments. Mr. F. F. Godley may use the apparatus as the agent of Mr. C. F. Phillips.

It is necessary to stipulate that the apparatus shall be used in such a manner as to cause no interference with other stations, and that this permit is subject to withdrawal or modification at any time at the Postmaster General's discretion should occasion arise.

(signed) J. W. Wissenden
for the secretary.

About the time I was ready to shift for Scotland it began to look, as the result of cablegrams received from members of a committee of the Radio Club of America, which had been appointed to investigate the reported reception of station 2QR in Scotland, that it would be desirable for someone to go to Aberdeen, make the acquaintance of Messrs. Miller and Benzee, and learn what he could concerning this reception. Final conclusions reached partly as a result of this trip have already been reported, and I greatly admire the sportsmanlike spirit shown both by Messrs. Miller and Benzee, and by the Messrs. Robinson on this side. The tendency on the part of British amateurs near London is to believe that the gentlemen in Scotland had heard a *British* amateur phone, and this would seem quite likely.

The Miller brothers were located in Aberdeen at their attractive little general store where they carry a full line of handy electrical appliances, clocks, watches, etc. They had dismantled their original station, but had in operation sufficient paraphernalia to enable their getting time signals. And, after a long drive by motor into the country I found Mr. Benzee at work in his radio shack beneath two very fine looking 80-foot masts. He had the best looking amateur antenna which I saw in either England or Scotland, and as I entered his station and had a look around I wished it were possible to place in front of him some of the fine equipment which is available to American amateurs, for he seemed to be doing exceptionally good work with a great deal of ingeniously gotten up but clumsy and, I fear, rather inefficient home brewed "gear". He was greatly interested

in everything we fellows over here are doing. He had the bug badly, and would come nearer to feeling at home were he to be suddenly dropped into the thick of amateur activities on this side than any other whom I met.

On Saturday evening Dec. 3d I arrived in Glasgow from Aberdeen and got quickly into bed at the Central Station Hotel. I had been nursing a cold, and was very desirous of resting up a bit, and shaking as much of it as possible.

On Sunday, December 4th, I came out to find the temperature about 30 degrees, and a very chillingly heavy fog. My log book reads as follows:

"Slept until noon in an effort to get warm. After mid-day meal, went out to look over Glasgow, but so chilled, gave it up after two hours. Returned to the hotel and hugged open grate fire in lounge, wrote a letter, had dinner, and went to bed to keep warm. No heat in hotel rooms. All shops in Glasgow closed tight on Sunday. During evening, also made schedules for following day, since tests began in 60 hours. To properly locate and make all necessary preparations calls for some hustling."

"Monday, December 5th, Central Station Hotel, Glasgow. Weather, 34 degrees and overcast. No fog. Present letter of introduction from Mr. Allen of Marconi house to Mr. J. A. Carswell of McNaughton Bros., Ltd., and found him busy, interested and agreeable. He sends his secretary with me to meet Mr. D. Sutherland, superintendent, Marconi International Marine Communication Company, Ltd., to whom I also have letter of introduction from Mr. Allen. Mr. Sutherland takes me in tow and I get tent, wire, insulators, accumulators, etc., etc., in very short order. Carswell, Sutherland and self lunch together. Very enjoyable. Leave Glasgow 4 P.M., Caledonia Railway for Ardrossan, arriving 5:30 P.M. (Eglinton Arms Hotel). Get large scale maps of Ardrossan, and try to choose likely site. A walk out in dark after tea shows all beach sites unsuitable account tides. Getting local color from Mr. Lee, proprietor of Eglinton, until 1 A.M.

Weather warmer and clear spots in sky when I turn in."

Mr. Sutherland was not particularly struck with the chances of my being able to secure the necessary materials and get them to Ardrossan within the time limits which I set. In fact, it took him about 20 to 30 minutes to get used to the idea, when suddenly he seemed to take great interest in the thing, and began to make the dirt fly. I was greatly pleased a few days later when he called me on the 'phone. The opening of the conversation ran something like this: "'Ello, 'ello, who are you? I say, Gadley, I want to congratulate you. I didn't think you would do it." (Meaning getting my equipment into operation

in so short a time.) Neither Mr. Sutherland's nor Mr. Carswell's interest stopped here, and they took advantage of every opportunity to get me on the telephone, to send mail and packages down by messenger, etc., etc., and they expressed a genuine delight when the good news reached them to the effect that our tests were successful.

I soon found myself with Mr. Wood, the town clerk of Ardrossan, and police officials, as well as several other worthy citizens enlisted in my cause. The day in Glasgow had been a foggy one, and I began to wonder whether or not my trip to Scotland was to be proved useless. At Ardrossan, however, the fog had cleared and was replaced by rain in great abundance. High, gusty winds were blowing, and although the tendency upon arrival was to sit tightly by the fire at the hotel, and bundle myself up, I went forth into the night in an effort to get the lay of the land. There remained but 30 hours before the tests commenced, and I was extremely anxious to locate that bit of ground upon which I might decide to erect the Beverage wire. The exploration of the night included a patrol of the beach south of Ardrossan, as well as the beach north of Ardrossan, both of which places on the map showed promise of being suitable for the purpose. I was very much downcast to return after three hours in this weather and after having found that both beaches were almost completely covered with water at high tide. The following morning further exploration was made, and at nine o'clock I met Mr. Carswell from Glasgow in the office of Mr. Wood, and the three of us proceeded to tramp around in an effort to locate a suitable site. The north beach was once more explored, and then at this point we were caught in an unusually heavy downpour and soaked to the skin, but not until I had finally decided that a certain field upon which we had had our eye would be suitable for the set-up. At this juncture we were invited into the home of Mr. Charles Murchie, and offered chairs beside a warm fire. I still shudder when I think of the awful thing we did to Mr. Murchie's rugs and polished hardwood floor.

We also used the telephone, got a Ford automobile, after some delay, and went off up into the country to locate the owner of the particular piece of farm land which I had chosen. I had been congratulating myself all along on the good fortune of having two interpreters with me, because I must admit I found considerable difficulty in understanding English as spoken in Scotland. When we finally reached the home of Mr. Hugh Hunter I greatly regretted my inability to talk the "brogue", because I was very grateful to Mr. Hunter for the great interest displayed by him in our project, which resulted in his allowing us to use the field.

At noon, Pearson, above-mentioned, came on the scene, and we immediately began transferring huge bundles of tent, storage batteries, trunks, floor boards, poles for the antenna, etc., etc., on to this field. It proved to be a very slippery field. It had been covered almost entirely with a heavy coating of seaweed which is used as fertilizer; and those who have had experience in walking over seaweed know that it is a very difficult matter. The one-horse wagon which we got to haul our paraphernalia on to the field was stalled several times, and it was only by unloading a portion of the equipment and carrying it, and



later by putting our shoulder behind the wagon that we were able to finally reach our destination. The poles were scattered down the field at 125-foot intervals, they having already been drilled to take insulators. Floor boards were spread on the ground, trunks and paraphernalia placed on them, and the tent erected. A laborer began digging holes for the poles, while Pearson, myself and one other man started erection of the tent. The tent had just been gotten nicely into position when an unusual heavy gust of wind lifted the whole affair and carried it away.

My log reads as follows: "Ardrossan, Scotland, December 6th. Weather warm, variable gales, with heavy squalls. Meet Mr. Carswell at office of Mr. Wood, Ardrossan Town Clerk, at 9 A.M., after further reconnoitering. Wood, personal friend of Carswell. We looked over maps, beaches and shoreward fields, and finally choose grass-covered fertilizer-covered field property of Mr. Hunter, about one and a quarter miles north of Caledonian Railway Station. Soaked in rain. See Police Sergeant and present credentials. Police find me a watchman. Arrange for transportation of tent, materials, trunks, etc., and order wire supporters from timber yards. Interview Mr. Hunter, and find him agreeable. Lunch. Inspector-operator Pearson arrived for checking results. Get men and all materials on field at 3 P.M., and attempt to erect 12 x 18 foot tent in gale and rain fails. Make very poor progress. Dark at 4 P.M. Continue work until 6:30. Distribute wire support poles, and lay out line for 1300 foot

wire, supported 12 feet above earth, on a line running approximately 26 degrees north of west (which is directly towards 9ZN). Rain and darkness finally drive us in. Pearson returns Glasgow for clothes, and I rig up small Western-Electric tube on Burgess batteries at hotel, and listen with makeshift regenerative receiver and an emergency 60-foot single wire antenna, and get gas pipe ground. Hear a good many 600-meter stations, and a great deal of heavy static on shorter waves. Small lighting battery expires after two hours and twenty minutes, and this, together with heavy cold and sore muscles, puts me to bed in a greatly depressed frame of mind, inasmuch as I had fully expected to get going full blast tonight. The chill and the whistle of a switch engine beneath my window prevents what should have been a sound sleep."

The following day, having enlisted additional labor, things were going in proper style. A line was laid out something under 1300 feet in length, and ten poles equally separated were erected, each pole being twelve feet above the ground and carrying a standard Post Office pattern insulator. A phosphor-bronze wire was then run the entire length of the line and grounded through a variable non-inductive resistance, the ground plates themselves taking the form of several short lengths of iron piping buried some four feet in the earth, at which depth we found one of the holes filled with water.

My log for December 7th reads as follows: "Weather warm, high winds, and driving rain with occasional slacking. All my clothes wet and heavy cold on chest. Two laborers meet me at hotel at eight (just getting light) and we proceed to the Lynn field. Rain has slackened to a drizzle, but walking on field extremely difficult because of its sogginess, and because the field is covered with slimy sea plants. By noon tent is erected, side walls up, and four poles up, the fourth one guyed. Pearson comes on the scene. We plant two more poles, and go to lunch. Darkness finds poles up and wire strung. We continue work in light rain, and bury several ground plates in wet, sandy soil at a depth of four and a half feet. End of line about 200 feet from telephone line (a good stone's throw from beach). Returned to tent, fixed lead-in, and then to hotel for late supper. Procured coffee, sandwiches and a bottle before returning to tent. Made table of boards, and trestles, chairs were boxes and apparatus trunk served as a back rest. A lantern and oil stove were set going, and we made ourselves as comfortable as possible, though small stove did little by way of heating big tent. Tubes, apparatus, high tension battery and storage battery unpacked and found all OK after their long and varied journey through

England and Scotland.

"By 11:30 the 3,000 meter amplifier, which will be used throughout in conjunction with super-heterodyne receiver, was going and "FL" (Paris) was picked up with no antenna connection. In completing set-up his time signals were missed but POZ (Nauen) at 12 midnight served as a check on timepieces. After time signals a 60-foot piece of wire was thrown into a tree for use in adjusting to short waves.

"Picked up many, many 600-meter stations immediately it is connected, and, using them, go through and carefully adjust all apparatus for maximum sensitivity. By about 1 A.M. we were on Beverage wire and feeling for short wave signals, and picking up harmonics from FL's spark and many high power continuous wave stations, although harmonics much less severe than near London, with the exception of Clifden-Ireland's, which are very strong.

"At 1:33 A.M. picked up a 60-cycle synchronous spark at about 270 meters, chewing rag. Adjusted for him, and was able to hear him say "C U L" and sign off what we took to be 1AEP; but atmospheric made sign doubtful! That this was an American ham there was no doubt! I was greatly elated, and felt very confident that we would soon be hearing many others! Chill winds and cold rains, wet clothes, and the discouraging vision of long vigils under most trying circumstances were forgotten amidst the overwhelming joy of the moment—a joy which I was struggling to hold within! I suggested hot coffee at once, and Pearson volunteered to warm it on our stove. He had pot and bottle in his hands when I called sharply to him to resume watch! Our welcome American friend was at it again with a short call for an eighth district station! His signal had doubled in strength, and he was booming through the heavy static and signed off clearly 1AAW, at 1:42 A.M.! Pearson only in time to get the AW on the tail end! We decided at once to leave settings and lay for him. About 1:50 he was in again, but recognizable only by virtue of his tone—totally unreadable!

"Having heard no more of him at 2:35, I returned from a five-minute run down the line to report a pole broken short off, and the line on ground at a point about 700 feet from tent. Winds very high.

"We shut down at 2:35 A.M., and repaired a break in wire, reset pole, and resumed watch at 3:10 A.M. Atmospherics were rising, and although no short wave signals from America, 600-meter signals were booming in with Cape Race readable with telephones on table at times. Closed watch at 6 A.M., after nearly twenty-one hours work of the worst sort.

"Wired Coursey: 'Rains, winds, atmospheric heavy. Working under tent.

Beverage antenna, which fell during night. Heard 1AAW calling eights 1:42 Greenwich, 270 meters, fading, sink gap. Ask him continue same time nightly. Keep all signals coming. Happy."

It might be well here to say something concerning equipment. I do not feel qualified at this time to enter into a technical discussion of the Beverage wire. I decided to use it because atmospheric, in the neighborhood of London, had been so strong as to make the use of the super-heterodyne impossible. The same atmospheric were encountered in Scotland, and although at one time I had intended to erect a fairly respectable vertical wire as a companion to the Beverage wire, thoughts of this were dismissed. For best reception at any given wave length, this wire should have a length equal to one wave length, and according to the dope given me by Beverage, should be grounded at the end toward the station at which the signal originates through a resistance of between 250 and 400 ohms. At the other end the wire is grounded through an inductance having an effective value of about 0.1 milli-henry (for 200 meters). This last inductance is coupled to the receiver, and adjustment of the resistance gives to the wire a decidedly directional characteristic, thus enabling the elimination of a great deal of interference and static. (I now doubt whether or not we ever had this wire properly adjusted for any wave length other than that on which station 1BCG was working, since in order that we might get proper adjustment it was essential that we have some signal to work on.) To make adjustments on this wire it was necessary to run back and forth from one end of the line to the other, and this was rather tedious work. But I have the satisfaction of knowing that we received the signals on the first night that the antenna was in operation, and that we had received a great number of signals prior to the time when British or Dutch amateurs had received any, notwithstanding the fact that according to calculations which Beverage has made, *the effective of height of our antenna could not have been more than 65 or 70 feet.*

The possibilities of the Beverage antenna in connection with reliable trans-continental and trans-Atlantic relay work are very well worth looking into. At this time I am satisfied that a goodly portion of my success is directly due to the use of this type of antenna. It is hoped that before long complete data concerning it will be available to amateurs.

As to the receiving equipment itself the only apparatus which I carried with me was a Paragon regenerative receiver, together with a Type DA-2 detector-amplifier, and a super-heterodyne receiver, which, including the external beat oscillator, had a total of ten tubes.

The Beverage wire was inductively coupled to the input circuit of No. 1 tube, which was a detector. The plate or output circuit of this tube was tuned regeneratively in order that advantage might be taken of regenerative radio-frequency amplification. The output circuit of this detector tube also included a closed oscillatory circuit, tuned to a frequency of approximately 100,000 cycles. The second tube was used as driver for an oscillatory circuit which, by virtue of its coupling to the input side of the first tube, supplied the detector circuit with oscillations of such a frequency as to produce beats of the order of 100,000 per second with incoming oscillations, this beat frequency being passed to tube No. 3, which is the first tube of the five-stage 100,000-cycle radio-frequency amplifier; all of the stages, excepting the last, are resistance-coupled, while the last is coupled through an air core transformer to a second detector, which in turn feeds one stage of audio-frequency amplification.

The complete circuit for the set-up as used is shown herewith. Inasmuch as various descriptions of this type of equipment have been printed in American magazines, no attempt will be made to go into great detail. Suffice it to say that the coupling resistances have a value of 100,000 ohms; the grid leaks a value of about 2 megohms, the grid condensers a value of about 250 micro-micro-farads. The air core transformer which couples the amplifier to the second detector is tuned to the frequency of amplification. Regeneration at the 100,000-cycle frequency is effected by capacitive back-coupling from the plate of the last radio-frequency amplifier to the grid of one of its predecessors. The cabinets containing the super-heterodyne equipment are lined with sheet copper. All condensers, resistances, leaks and tubes which go to make up this amplifier are selected with great care, and in addition it frequently proves advantageous to shield the cords and cases of the telephone receivers, the shield being connected to the negative terminal of the "A" battery.

For reception of continuous wave signals it will always prove more convenient to set up a tenth tube which drives an oscillatory circuit for this purpose. Usually it is better to set this oscillator so that the third or fifth harmonic of the oscillation which it produces falls near the frequency of amplification—this because it is difficult to control the amount of energy fed into the amplifier when the fundamental frequency itself is used for beat production.

On Dec. 8th my log reads as follows: "Weather: High winds and heavy rainfall, changing to clear with northwest winds at midnight. Star-filled heaven and a half moon—a welcome and beautiful sight.

Such a night should be ideal for our purposes.

"Line properly repaired during day and early evening spent trying to get dry at Hotel. Apparatus found in good shape, and constant watch kept until 6 A. M., with no amateur signals heard. Cape Race on 600 meters much weaker than last night. At 4:30 A.M. Pearson goes out and makes a shift in line to ground lead but no signals result.

"Attempt to receive C.W. stations blanketed by high power station harmonics, and the few breathing spells which Clifden takes are welcome ones. If poor weather instead of clear is required for signals it is to be hoped that we have poor weather.

"Clear spell brings greater chill and we shift table a bit and hang canvas to our backs to keep the wind off. A heavy cold which I have been fighting settles further into my lungs. Pearson being a Scotchman seems to be immune, and no doubt would suggest that I don't drink enough of Scotland's Honeydew.

"Wired Coursey: 'Cooler, clear; moderate atmospherics, no signals.' Closed down at 6 A.M., somewhat disappointed, but thankful for yesterday's great encouragement."

December 9th the log reads as follows: "Weather again wet and boisterous and at midnight on cutting in, find atmospherics very heavy, but wind dies away by 2 A.M.; rain continuing to fall, and atmospherics falling off to moderate strength.

"At 12:50, after listening some time for free-for-all sparks, we swing over to C.W. and it is indeed a thrill we get when 1BCG is picked on 230 to 235 meters. A harmonic from Clifden is jamming but after some adjustment this is partially nullified. Signals from 1BCG very steady and reliable. *Remarkable performance* and I wonder what power he is using. Lose him many times in an effort to 'feel out' the Beverage wire, but get him much better after adjustments terminated at 1:33. He is calling 'PF test' and signing. Sweetest song I have ever heard. Calls separated by (?). Changed operators at 1:45 A.M. His sending steady in all cases. He fades out for 30 seconds every 3 or 4 minutes, but always comes back strong and steady.

"At 1:59 A.M. he calls 2BGM and says 'Phone us now', then shuts off. Measures between 230 and 235 meters on little General Radio meter.

"Pearson and I relax, laugh with glee, and start looking for something to eat and drink.

"Continue through night to hunt for more, but without avail. Static fairly bothersome, and Clifden is sending a great deal, and am unable to shake him.

"Shut down 6 A.M. but start up again after talking it over, to copy MUU. MUU sends 'Godley's message'. It comes home

to me that ours is a history making set of tests—that American amateur radio has the world by the ears. I would give a year of my life for a 1-KW tube transmitter, a nice, upstanding aerial and a British Post Office license to operate it on 200 meters. To be forced to listen to a Yankee ham and *only* listen is a hard blow.

"Wired Coursey: 'Burnham owes Warner new hat. Warm rains, calm, decreased atmospherics. IBCG calling me ending two Greenwich. Undamped two thirty, strong, steady. Congratulations.'"

The performance of IBCG had filled me with a lot of very wonderful feelings. Pearson and I spent considerable time in talking it over and trying to figure out what his equipment might be. It was hard

kindly mood! Signals were there! But, alas, I had not counted correctly on the vagaries of men's minds! Some British telegrapher against whom I shall carry a grudge to my grave had "bulled" my cable, for it reached Armstrong reading "SEND MGES", and he did! He sent "MGES" over, and over, and over until I was sick! He kept it up the entire night, regardless of schedule, and no earthly way of stopping him! I remember getting a laugh out of it by conjuring up pictures of the "Old Man" spitting on the cat, but I could not forgive myself for exercising so much thrift. I wished that I had sent cables to Hartford and home and to Warren G. himself apprising them of the facilities available, for then I am quite sure my ideas

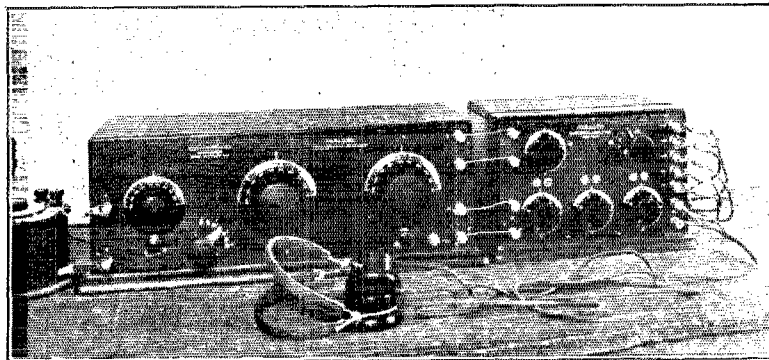

Special regenerative receiver, range 160 to 500 meters, used at Ardrossan and London.

for Pearson to believe that only 1 KW had been used, while I felt quite certain that the legal limit had not been exceeded. The frequency of the wave was *unusually* steady, and for this reason it had been possible to build up excellent signals by taking advantage of resonance in the telephones. To offset this belief, however, there remained the fact that we had not even heard indications of other stations after IBCG shut down at 1:59 A.M. and I began to wonder whether or not IBCG might be the only station which would get over in real style. I then decided that no one thing would forever redound to the credit of amateur radio more than the transmission and successful reception of a complete message and I wired Armstrong direct as follows: "Signals wonderful send messages starting one Greenwich" and went to bed with a singing heart and thoughts of the coming night when we would be copying (perhaps) messages via IBCG from Hartford, and my home, and even from Warren G. Harding himself—who could say.

And, when we were on watch again it was "Allah be praised!" Nature was in a

kindly mood! Signals were there! But, alas, I had not counted correctly on the vagaries of men's minds! Some British telegrapher against whom I shall carry a grudge to my grave had "bulled" my cable, for it reached Armstrong reading "SEND MGES", and he did! He sent "MGES" over, and over, and over until I was sick! He kept it up the entire night, regardless of schedule, and no earthly way of stopping him! I remember getting a laugh out of it by conjuring up pictures of the "Old Man" spitting on the cat, but I could not forgive myself for exercising so much thrift. I wished that I had sent cables to Hartford and home and to Warren G. himself apprising them of the facilities available, for then I am quite sure my ideas

correctly interpreted. My log for December 10th-11th reads: "Got on job a bit before twelve feeling very fit as a result of extra bit of sleep during afternoon and evening. Was most worn out. Take time signals from POZ and then do a bit of rearranging. I rig up external heterodyne for beating on my amplification frequency, hoping this will be better than using amplifier as autodyne, because of greater ease of adjustment.

"Get set at about 12:50, and at a few minutes past one, pick up IBCG, sending 'Mges' over and over. Signal very strong and steady. Static very strong too, and have considerable difficulty to get signal-to-static ratio up. He fades more than last night. At 1:14 he says: 'three minutes'. I expect him to start sending messages, so anchor on him, making adjustments for improvement from time to time, and am very thankful for such a fine signal to work on.

"Pearson makes frequent excursions up and down the line, and endeavors by every means to get the static out and get the signal, but at 1:15 he faded out.

- 1:16—There, but unreadable.
 1:17—There, but unreadable.
 1:18—Faded out.
 1:20—Returned a bit. Static getting heavier and adjust to reduce. Now have him saying "Mges" over and over.
 1:22—Faded out 10 seconds and back.
 1:23—Faded out 20 seconds and back.
 1:24—Faded out 10 second and back.
 1:25—Weaker.
 1:26—Weak but steady.
 1:27—Very weak and very steady.
 1:28 and 1:29—Coming up very strong and steady.
 1:30—Fades a bit.
 1:31—Long dash, very strong and steady.
 1:32—Fades a bit, but back again.
 1:33—1:45—Very strong and very steady. Says "GE PF" and stops.
 1:50—Back again, after five minutes shutdown, and new operator now.
 1:51—Says "Minute, minute sn" and shuts off.
 1:53—Long, unsteady, bubbling dash, and immediately much stronger than at any other time. Can read him throughout tent with 'phones on table, and wind howling outside. "Tests VV Mges de IBCG", etc., etc.
 1:57—Falls off a bit, but still good, saying "R R Mges de IBCG."
 1:58—Fades to just audible for 20 seconds.
 1:59—Coming up.
 2:00—Just audible and out five seconds.
 2:01 to 2:04—Strong and steady.
 2:05—Almost out for 20 seconds.
 2:06—Readable—back to normal and now reading 'phones down.
 2:07—Subnormal—slowly weaker, out five seconds, rising and falling. Static still quite severe, much worse than last night.
 2:08 to 2:12—Readable, rising, falling, weak. Suddenly jumps to normal for ten seconds, and fades to readable.
 2:14—Stronger.
 2:15—Says "Three minutes."
 2:18—In again, now another operator sending.
 2:21—Continuing good and steady.
 2:23 and 2:24—"PF PF de IBCG Test Test", etc., etc. Fine, steady and strong, fading a bit, but never out.
 2:27—We jarred oscillator off setting and lost him, but back OK.
 2:31—Says "Min bi 3 mins" but starts immediately and says "QRV".
 2:32 to 2:38—Weaker but readable.
 2:40—Accumulator failed, lost him in making change.
 2:53—Going OK "Godley Mges."
 2:56—"QRV"
 2:59—He pauses. Very strong and steady during this period.
 3:02—We talk and miss a phrase.
 3:00 to 3:15—Very strong and steady.
- Says "Bi 3 mins de IBCG 30." We go out and stretch.
 3:27—He is just now starting with another long dash and says "QRK Godley?" Another operator now. Signals thoroughly uniform. He sends "PF" in American Morse, probably John Grinan.
 3:40—"PF" in American Morse twice.
 3:43—"ZE" twice. He has been wonderfully uniform since 3 A.M.
 3:49—Pick up IARY, saying "QRV".
 3:53—IBCG comes in again. Also following from IARY: "From IARY to 2VA—we will play again at football next fall. No sig." "2AJF from IARY No sig. HW 2AJF de IARY ar."
 3:55—IARY very slowly: "next fall no sig. 2AJF de IARY". Very steady.
 3:57—IBCG still going *strong*, steady, and sharply, says "30" at exactly 4 A.M.
 4:02—In again, very strong and steady.
 4:05—Decide IBCG is not going to send messages so leave him. Static fallen off rapidly in last hour, and wind has gradually shifted from southwest to northwest. Getting colder. Clears up a bit, but begins raining again about 4 A.M.
 4:10—Some continuous wave calling 4GY. Can't read him for static.
 4:17—IBCG still steady and *strong*.
 4:18—Stops for a few minutes.
 4:19—IARY calling IUN (CW) weak.
 4:21—IARY still calling IUN.
 4:23—IBCG still in; sends few V's.
 4:26—IARY calling 9BBF. "Here msg."
 4:30—IBCG says "Three minutes AS". Some spark in too, but unreadable.
 4:35—Several CW's and spark in, one CW quite loud but jammed. He is saying something about a message from "Richmond for West Palm Beach". From his fist suspect it is 4GL.
 4:37—"R R Hello, Godley de IBCG." Still very steady and fine. IARY calling 9BBF again, *seems fully as strong and steady now as IBCG*.
 4:43—"Hello Paul de IBCG".
 4:49—2FD calling 9XAH (CW). Fine, clear and strong. Pearson marvels at proficiency of amateur operators.
 4:53—8ACF calling CQ (CW).
 4:54—2FD calling 9XAH, says "GE".
 4:58—IBCG still *very steady*. "Bi".
 5:03—IBDT (spk) calling 2OM says: "GE 73 QTC." IARY (now spk) calls IBIS. Both above fading.
 5:09—Several sparks in too faint to read.
 5:10—IBDT calling IDY.
 5:14—IBDT calling IDY. (FFU jamming.)
 5:15—Some buzzer calling 3PU.
 5:18—2FP (ICW) in strong, very fine, steady signals. Sending his code word "HUZZJ."
 5:23—IRU (CW) in strong and clear sending his code word "BPUSC". IRU signs off at 5:25 A.M. 2FP still going

February, 1922

Q S T

27

and can hear him all over tent. Very steady. Signs off at 5:30 A.M.

5:30—2BML in strong, steady, but his note varies considerably. Must be blowing at Rocky point and I wish Beverage could come up from Chelmsford and listen to his rotten note. However, Beverage is "there" on the antenna design. 2BML is sending his code word over and over very carefully and slowly, "FSXVG". He is much easier to read unheterodyned.

5:37—2BK is in (spark) working locals he says "OK tried anything yet OM".

5:40—1BDT in working a 3 station.

5:43—1BGF calling eight station.

5:44—1BCG still *going strong*. "V's".

5:49—8XV sending "Test" (CW.)

5:53—1YK calling 8AQV (CW). "LXCAM" coming through the QRM but cannot get his call due to jamming and his fades.

5:55—3BP (spark 60 cycle synchronous) Very strong.

5:57—LXCAM in again, but don't get his call. (500 cycle modulated CW).

6:00—1BCG "Test Godley". Still steady.

6:03—1XM signing off, ICW. 2EH (CW) calling 9ZJ—both good, but don't hear 9ZJ sign, although recognized his note and his fist.

6:05—2BK calling 8AYN. Strong.

6:19—2DN calling 8AYN; also strong.

6:23—1XM in, 500 cycle note, may be spark.

6:31—Someone says "Must put some wood on fire, old man." Think it is 2EH again.

6:39—A squeak box freaks in, and I am dumb-founded until I learn it is a French vessel. (FFV jamming.)

6:43—2EH (CW) calling 8AAH.

6:50—Close down to get a check on MUU. Colder; wind now in north. Very dark. A glorious night! And I hope that some of the English boys have had a look-in too. Surely, with their high frequency magnification they should do wonders on a night like this. I hope they have. I get a great deal of pleasure out of thinking about the glee with which MUU's message will be received tomorrow morning. How Warner will measure his head for the new spring hat! How old man Maxim will carry a face split from ear to ear. How Armstrong, Grinan, Burghard, King, Amy, Cronkwhite and Inman will go around with chips on their shoulders and chests stuck out. 1BCG is *some* station, and Pearson and I both agree 1BCG was commercial signal 3 to 6 A.M. Some of the boys will be very much surprised too, because have heard some who never dreamed of getting over.

"The feature of the evening was the very fine and steady signalling from 1BCG. His continual transmission enabled a series of careful adjustments all along the line for a maximum effectiveness of antenna and

apparatus. Towards the last of test static had decreased, and was able to get "clear air."

"The patience and clocklike precision of shifts at 1BCG is deserving of great credit. Pearson is greatly impressed both by the enthusiasm displayed by all amateurs in America, and by the way this receiving outfit works.

"I am anxious for news from home, and cabled 1BCG as follows: 'Send home news.' Wired Coursey: 'Heard 1RU BPUSC, 2FP HUZXXJ, 2BML FSXVG, also spark 1ARY, 1BDT, 2BK, 2DN, 3BP; undamped. 1ARY, 1BCG, 1BDT, 1BGF, 1YK, 1XM, 2FD, 2EH, 8ACF, 8XV, strong, reliable, thrilling.'"

In connection with this night's results, the following is to be noted, that the reception of so many signals was a combination of adjustments resulting from having station 1BCG to work on, and of transmission conditions which seemed, after several hours' hesitancy, to have decided finally to let through a great number of stations. The extent to which this condition persisted is evidenced by the fact that, whereas during the early evening and prior to a series of adjustments of the Beverage wire it was just possible to read 1BCG through static, later the combination of static-eliminating adjustments and conditions made it possible to read *at least two stations whose output is not greater than 30 watts*.

Subsequent to 4:30, many sparks and CW signals would come flicking in for short periods of time and then go out again, before it was possible to get their signs, and in many cases to even hear what they were calling.

I cannot at this time too heartily condemn the practice of stations working locally without using their call letters. On at least a dozen occasions I very carefully tuned in stations to listen to them for periods ranging between one and three minutes, to find that my effort had gone for naught, since the stations in question suddenly stopped working without using their station calls.

Between 4:30 and 6 there were times when so many stations came in that it was impossible to read any. At such times as these I was very strongly reminded of the interference conditions near New York City. These conditions were duplicated exactly, excepting that the strength of signals was not as great. The number of stations audible; however, was fully equal to the number audible when listening in, in the vicinity of New York.

Monday, December 12th:

"1 A.M.—In late, account finishing up log. On at 1 A.M. adjusting on 600 meters. Partly cloudy, north wind all day, now southwest, but remains cooler. No rain today.

1:25—Go to short waves. Static intermittent, medium heavy clicks. Several American amateurs in too weak to read. 1BDT sending "Test", spark very strong and steady. "Transatlantic tests". Strong harmonic from some H.P. station, sending press and fading in and out. 1BKA sending "test" (CW). FFU jamming. 1XM (ICW sending "test". FFU jamming. Dozens of them in working, wonderful.

1:45—1XM in again.
1:50—1BCG says "Bi 1 hour."
1:55—2EH (CW) "Test." Lots of jamming from the Holland stations.

1:58—2FP in strong. (ICW).
2:05—2ARY (ICW) "Test". Lots of QRM from Poldhu's press on harmonic. Other press schedules also going, and all seem to have harmonics. Makes it difficult.

2:11—3FB spark. "Test." (QRM FFU.)
2:19—2AJW calling 2OE (CW). (30 watts.)

2:24—2EH (CW) calling SAKV. (UAT arc jamming.)

2:35—2EL calling. (Weak.)
2:39—1ARY (CW) working.
2:50—2EH calling SAFD very steady. 1BCG in with messages.

2:52—He starts: "Nr 1 de 1BCG words 12, New York. Date December 11, 1921, to Paul Godley, Ardrossan, Scotland. Hearty Congratulations. (Signed) Burgard, Inman, Grinan, Armstrong, Amy, Cronkhite." Received from 1BCG finishing at 3 A.M. He says "Bi two hours". (Last heard of him.)

3:03—2EH working 2XQ. Very steady.
3:11—1RZ in (CW), readable; also many weaker ones jammed by high power stations.

3:15—Shut down for slight shifts. Had small regenerative receiver in. Heard several CW stations faintly, but only one readable.

4:05—Back on super-heterodyne receiver. Apparently all faded out. Hear only an occasional 20-second amateur spark or continuous wave, and no more. Weather again changing here. FFU, who has been jamming all evening, is rising and falling rapidly, being very weak most of the time. Battery getting low, but do not blame it.

5:54—Heard nothing more.
6:05—Nothing more. Close down. Wired Coursey: "Code LXCAM call jammed, also 1BKA, 1RZ, 2ARY, 2AJW and 3FB."

"December 13, Tuesday—On 1:30 A.M. account oversleep, after up 24 hours straight. Partly cloudy. Bright moon. Wind northwest with occasional squall. A bit frosty.

1:30—Nothing in on short waves. Go through amplifier adjustment. Medium static. Medium to moderate clicks, and a good deal of interference from high power press-sending stations.

1:45—Wind begins rising rapidly and

cold getting intense. Ship stations going strong and static quite heavy on 200 meters, though much better than on vertical aerial. Nothing in on short waves which can be read.

2:10—Static growing worse. FL's arc jamming too.

2:15—Continuous wave station in on 225 meters, but can't make him out; and it is even difficult to get him turned on account of atmospheric. Atmospheric seem to have reached a sudden peak, and now are steady, louder crashes having flattened out into continuous roar.

2:40—Static killing everything, can't even read harmonics nearby from high power stations.

2:55—Swapping tubes for improvement of amplification. No marked improvement over those picked initially.

3:00—Static increasing, still bright moonlight, and partially cloudy. Wind still in northwest. Out for eats.

3:15—Static increasing and occasional squalls and cold rain.

3:22—Carefully tuning oil stove and succeed in increasing output 50 per cent.

3:25—On 600 meters, comparatively quiet.

3:30—FFU on 600 meters. Have not heard him on 240 tonight.

"Note: Although on all previous nights we have looked diligently for stations on 250, 275, 325, and 375, none are to be heard even when conditions seem at their best, at which time very fine signals are coming through from Cape Race on 600 meters.

3:30—Pearson calls this a "proper washout."

3:40—Harmonics from high power stations only. Clifden's very loud.

4:00—Static continues heavy and continual muffled roar. Hearing nothing on short waves.

4:01—Fairly strong, unsteady CW signal on 1BCG's wave, send V's; fading fairly strong at times. Lose him entirely trying to better him.

4:24—FFU begins floating in on 240 meters.

4:30—FFU faintly through static on 450 meters.

4:45—On 600 meters, static heavy there too, and not much doing. Hear no sign of Cape Race.

4:50—Some 500 cycle spark on 200 meters calling CQ, but do not get his sign.

4:52—Non-synchronous spark, loud, sounds like British commercial station, but don't get his call.

5:05—Nothing coming through, static falling off a bit, but rather severe yet.

5:15—Nothing doing.

5:30—600 meters very quiet. Static clicks coming in again. Pearson getting very sleepy. Shut down to go over the line and eat a bit.

(Continued on page 36)

tube is nearly twice as much with tuned transformers as with untuned ones.

Reducing Fig. 1 for practical operation, L and L_1 may be the primary and secondary of a variocoupler similar to that of the standard regenerator. C is the series condenser generally used and C_1 is a secondary tuning condenser. L_2 and L_3 the transformer primary and secondary respectively, should consist of 30 turns of No. 20 magnet wire on about a 3 inch diameter and preferably arranged so that the coupling may be varied. C_2 and C_3 are the tuning condensers for the transformer and should have a capacity of .0005 mfd. C_4 is the detector grid condenser, usually of .0003 mfd. R is the stabilizer or C-battery potentiometer and should have a resistance of at least 200 ohms. One of the A-battery potentiometers now available will serve the purpose admirably.

The circuit will be found rather critical in adjustment but should give good amplification on 200 meters. Since the transformer has low resistance windings and hence a sharp resonance curve, it will only cover about twenty meters with good amplification for a set tuning adjustment of condensers C_2 and C_3 . In adjusting, a buzzer exciter may be coupled very loosely to the ground wire until proper transformer tuning and adjusting has been found.

Figure 2 shows an arrangement that has given remarkable amplification making use of the standard regenerator. L_1 and L_2 are the variocoupler primary and secondary, V is the grid variometer and V_1 the plate variometer. C is the usual series condenser and C_1 the detector grid condenser. The plate variometer acts as the radio-frequency transformer. The operation is identical with that of the standard regenerator with *no additional adjustments*.

In all of the circuits using tuned transformers (as above) a regenerative amplification is experienced in the first tube when the transformer primary or the plate variometer is brought near resonance, the theory of which is similar to that of the tuned plate regenerator.

The principles of radio amplification are ideal for our short wave work whereas the principles of audio amplification are all wrong.

In comparing radio amplification with other methods, choose a weak signal and not a strong one as from the above it will be seen that weak signals are amplified as much as strong ones, which is not true of the other methods.

But little data is available on short wave radio amplification and it is hoped that the above information will at least lead to further discussion on this most important subject.

Official Report of the Second Transatlantic Tests

(Continued from page 23)

6:00—Nothing in.

7:00—Copy MUU's report.

"Wired Coursey: 'Include yesterday's SBU stop. Heavy atmospherics today.' (SBU logged by Pearson.) Coursey added to this: 'Many your stations heard by British amateurs. Details later.'"

December 13th—14th:

"In bed all day trying to keep warm and catch up on sleep. Get out a bit late. A cable from Clement via Coursey saying 2XB will transmit 450 meters continuously, CW, ICW and telephone 1 to 7 GMT this morning. A letter from Coursey saying 'They have been heard' in London, on British equipment and 'small British aerial'. I am very much pleased.

12:45—Find line and tent OK. Inspect grounds and start stove. Cold west wind, overcast, fleecy clouds. Static grinders. Clifden's harmonics particularly bad. POZ also has a strong harmonic going. FFU in good and strong and fading at 240 meters; also a harmonic from Poldhu, good and strong.

1:03—Some spark in, jammed by FUU and Clifden.

1:09—GMH in strong on 200 meters harmonic, also FFU.

1:25—Nothing of 2XB. Harmonics pretty bad on 450 meters.

1:30—GMH in. Also someone starting an arc.

1:45—Harmonics exceptionally bad; signals numerous on 300 and 600 meters. A great deal of intership work done on 300 meters in European waters. Dozens of ships near Firth of Clyde continually jammed everything near that wave.

2:00—Harmonics.

2:12—MFT's harmonics bad. GMH comes fading in and out on 200 meters; also JJT. Static comparatively light until now; increasing rapidly.

2:15—FBA on 500 cycle spark. FGR in on 320 meters.

2:30—GMH—PAF in, 450 meters.

2:40—PCB in, 450 meters.

2:45—Nothing in on 450 meters.

2:45—Static coming up; sounds like something charging and discharging, with a squeak. High west winds, quite cold.

2:50—Poldhu's harmonics freak on 200; also an American amateur freaking in and out. Non-synchronous gap. (Later more like GMH.) FFU fading in and out. This is a harmonic of his 600 meter wave, as is GMH's signal.

2:55—Very tired and sleepy.

3:02—Wind rising rapidly, and getting very cold.

3:10—Decide to turn in, nothing doing, and both greatly in need of rest.

"Wired Coursey: 'Colder, high winds, faint signals only. No reception.'"

It was on this night that Pearson had fallen asleep. The cold was particularly hard to bear. The wind whistled around our feet and came down in gusts on our heads. We pulled the oil stove around (it was directly underneath the table) and turned our boxes over so that our heads just stuck above the table. In this way the greatest possible portion of our bodies was exposed to what little heat was radiated by the stove.

Some time between 3:10 when we decided to turn in, and five o'clock, when we actually did turn in, I also threw my hands across the table and fell asleep. How long I slept I do not know, but I awoke suddenly with thoughts chasing around in my head to the effect that the "works" was on fire. In coming to I also awakened Pearson, who looked at me with eyes aghast. I immediately asked him if I had startled him, and he replied "What is the matter with your face? It is as black as ink."

The oil stove had taken a notion to smoke, and a good many of the papers, the log book, and a part of the apparatus, as well as the under side of the table, were thoroughly smoked up. My face laid across a crack, and when I had reached the hotel and had an opportunity to examine myself in the mirror, I could well understand Pearson's surprise.

It is growing rapidly difficult for me to remember the lack of enthusiasm on the part of both Pearson and myself to drag ourselves out of a warm corner by the open fire in the lounge at the hotel, in order that we might don rubbers, overcoats, and rain coats, and march out into the awfulness of the Scotch night, only to sit on a hard wood box in a very drafty tent. I remember several times wondering if this test would ever, *ever* be finished. As long as signals were coming in, there was plenty to keep one interested, and the nights passed very rapidly, but it was a continual fight against static and harmonics and cold and wet that drove one almost crazy.

In addition to this I was having to contend with a very heavy cold. I was subject to coughing spells which shook me from head to foot, and after which I felt as weak as a baby.

On Wednesday, December 14th, I almost decided to give it up. I had no hankering for an attack of pneumonia in Scotland, and I was advised on two occasions to forget all about radio and go to bed, unless I wished to be confronted with a serious illness of three or four weeks, with hospital attendance which was none too good. I am quite sure at this time if I had seen any weakening on Pearson's part I would have been only too glad to take advantage of it. I would like to say that I not only have the highest regard for Pearson's ability as an operator, but also for the courage—and

courage is the word—which he displayed in sitting up night after night, in a leaky tent, with high winds blowing, and heavy rains falling, and nothing but an occasional "wee drapple" and a very unreliable two-dollar oil stove to keep him warm.

At this time I was suffering from pains in the back, sore muscles, headaches, and a very stiff neck. However, towards the end of the week the weather was quite like summer, being very warm, and gentle southerly breezes were blowing, and we managed to carry on.

On Wednesday and Thursday, December 14-15, my log reads as follows:

"10:30—Very light static. Only thing to be heard on amateur waves are harmonics from 600 meter stations and harmonics from "Olympic's" tube set. Listening diligently on all waves, up to 12:10, nothing doing.

12:30—Dead silence, except for Clifden's harmonic, and an occasional 600 meter harmonic.

12:45—Go to vertical antenna. FFU's harmonic stronger and static heavier. No signals. Winds changing from west to north.

At 1 A.M. Poldhu's 200 meter harmonic comes in on his press schedules. Fading in and out. Static coming up rapidly since change of wind.

1:13—FFI in on 200 meters (harmonic.)

1:15—Static worse. Pearson goes to end of line and readjusts resistance, resulting in marked improvement in static.

1:30—MPD, FFU, and FFI in on harmonics. Nothing more.

1:45—Ditto.

2:00—Go to 450 for 2XB.

2:30—Nothing from 2XB. Static again getting stronger.

2:45—FFU in occasionally, nothing on short waves.

3:15—Absolute void of signals.

3:30—Both getting so sleepy we can hardly see.

3:45—Still sleepy. Still no signals.

4:00—Ditto. Ditto.

4:30—Conditions have been the same for hours. No signals. We decide to turn in.

"Wired Coursey: 'Bright moon shine, summery weather; only weak signals since the 12th.'"

Thursday and Friday, December 15th and 16th, log reads as follows:

"12 Midnight—600 meter signals more abundant than usual, but considerable static; go to 200 meters, and find static much worse. However, FFU's harmonic a bit stronger than usual, and FFI in occasionally on harmonic. Been like a summer's day here, and wind blowing from east and a bit south. Up all day getting photos of set-up; also had several visitors during afternoon, and for their benefit got signals from WKQ and POZ and several others.

12:30—Static heavy and no signals.
 12:45—Ditto.
 1 A.M.—600 meters going strong, static bad on 200.
 1:15—FFH and FFI in on harmonic. Clifden very noticeable account his absence tonight.
 1:30—Now raining hard, and wind rising. Static so bad can't read FFU, which is unusual.
 1:45—Static seems worse, but Poldhu's harmonic on his press schedule comes in very loud.
 2:00—Static very strong on 200.
 2:07—"Pace" and FFI working, also KBH working on 300 meters.
 2:11—Clifden starts up.
 2:15—Static so bad we shut down for a look around.
 3:30—Static very heavy. No signals.
 3:45—Clifden and FFU only, latter unreadable.
 4:05—FFU in—readable. Nothing else.
 4:11—GCC harmonics in, just readable through heavy atmospherics. Wind blowing fairly hard, and getting cold in tent.
 4:30—Harmonic from some Marconi CW ship-set in, swinging badly, but loud; also GCC's harmonic.
 4:35—YBV calling ZAZ; somebody calling YBV.
 4:40—Static continues heavy. No signals. Weeps! Shut down. Blowing and raining like Old Harry.
 5:15—Static continues to increase, and much colder, and blowing and raining hard.
 5:30—FFU in, and Clifden going, also bubbles from some arc. Can't read FFU, though his signals are fairly strong, at 5:45.
 6:00—Closed down. Wired Coursey: "Atmospherics, no reception."

When the original schedules were laid out, it was with a view to enabling me to complete tests and return home in time to be with my family on Christmas Day. These plans were made on the spur of the moment, and on the assumption that it would be possible for me to pack up my apparatus, get it aboard train, and reach Southampton by noon of Saturday, the 17th. After it was too late to change these plans it became obvious that such a course would be impossible, and so, before leaving London, I had booked passage on the Olympic, which sailed on the 21st. In order to catch the Olympic, pay proper respects to various men who had been of great assistance, and get my apparatus checked out by the Customs Officials in Southampton, it was necessary that I arrive in London not later than Monday.

In order to do this, it became more and more apparent that we would have to dismantle on Friday and forego the additional night of listening which should have come in according to schedule. All business houses in Glasgow close promptly at noon

on Saturday, and it would have been impossible for me to return batteries, tents, wire and other paraphernalia which we had borrowed, get my apparatus back and aboard train *prior* to Saturday noon. After considerable indecision, and after waiting most of Friday to see whether or not the summertime conditions which had been with us would change for more favorable ones, it was finally decided, after 3 P.M. on Friday, to dismantle. This we started to do, and by seven o'clock that evening we had everything packed and were loading it aboard a wagon. By nine o'clock everything was in Ardrossan, properly packed and labeled, and we were all set to take the first train in the morning for Glasgow.

During the night, Friday, the tail end of the cyclone which had passed across the Atlantic during our tests hit Scotland, and we were indeed happy that we had dismantled our equipment, because the winds that night were higher than at any time during our tests.

This same storm by the following morning had backed the waters in the English Channel up until the tide stood at a depth of two feet in the streets of Hull, this being the same storm which had battered the Olympic in her voyage across, resulting in the death of two men and the destruction of several thousand dollars' worth of equipment on board.

It may very well be that this storm played some part in the success of our Transatlantic Tests. Starting in the Gulf of Mexico on December 9th, the storm passed up our Atlantic Coast to Newfoundland, and then out to sea. A clipping from the London Daily Express, under date of December 20th, reads as follows:

"Cyclone breaks loose. Demon career of gales and floods. Hurricane and raging seas in the Atlantic! Tidal floods on the northeast coast of Britain, and destructive gales in Scandinavia were widely scattered. Weather phenomena that it is now possible to trace to one cyclone which swept across from America to Europe. It originated somewhere about December 9th in the Gulf of Mexico, and swept northwards out to sea, gathering in fury on its way, and then it continued its career to the northeast, and no more was heard of it until three days later. It was rediscovered on Friday evening, however, approaching from the southwest, and about 1 A.M. on Saturday morning the liner Megantic, steaming on a northerly course to pass the north of Ireland, was caught in its giant grip. It then lunged eastwards, and swept across to Norway" * * * *

Now, as it happens, all of the signals heard at Ardrossan were logged during the time when this cyclone lay between the receiving station and the United States. After it had passed to the north, no further signals were heard. Weather reports clipped from British newspapers during that period seem to give little bearing on this particular storm, although it has been admitted that the weather during the entire period was under its influence.

Some time during the test I received a

letter from London, which included the following poem:

If our climate is un-Godley,
 If the weather seem to Paul,
 If our static strikes you oddly,
 If you hear no sigs at all,
 If you get harmonics down the scale,
 As far as tuners go,
 If the dialect in Scotland,
 Doesn't sound like Ohio,
 If twenty thousand hard boiled hams
 Are waiting on your word,
 If but the thought of hearing them
 Seems very near absurd,
 If, in the chilly morning hours,—
 The faintest sigs come thru,
 We'd like to hear about it,
 If it's all the same to you!!

I met the fellow who wrote this. His name was Harris, but his initials I don't recall. He didn't look the poet either, although he does, I believe, edit one of Britain's best popular scientific magazines called "Conquest", at which he shows even greater proficiency than at writing poems. And some chap in Belgium bravely showed his mastery of English by coming through with this:

A wise old owl lived in an oak.
 The more he saw, the less he spoke.
 The less he spoke, the more he heard.
 "Hams" should imitate that old bird.

Which I had a great notion to forward to Harris with his name substituted for the first word in the last line.

Coursey began to "ride" me a bit about this time too, with: "Aren't you sorry you didn't stay down here in the warm? Signals have been heard here on our small aeri-als", etc., ad nauseum!! I would have enjoyed nothing more than to have had the London crowd on that seaweed-covered field.

Congratulations began to come in too, not only from England and America, but also from France when our friend Deloy showed that he was on the job by the following:

"Hearty congratulations for your success. Here atmospherics very bad especially last night".

Such things as this helped when we needed it. It was quite the rule to get on the job during the afternoon and find that, for some reason, several poles were flat on the ground. We were never able to ascertain whether they had been broken off by some "animal" or whether the winds had reached sufficient velocity to do it. On many occasions the wind was strong enough to bend the 2x4's which we used for poles several inches out of line, and their continual "working" in the soggy ground as the result of gusts probably had a great deal to do with their falling. We finally had four stays on each pole, after which no further trouble was experienced.

Prior to leaving Ardrossan, Mr. Martin of the "Ardrossan & Salt-Coats Herald" interviewed me concerning the import of the tests and their success. This interview

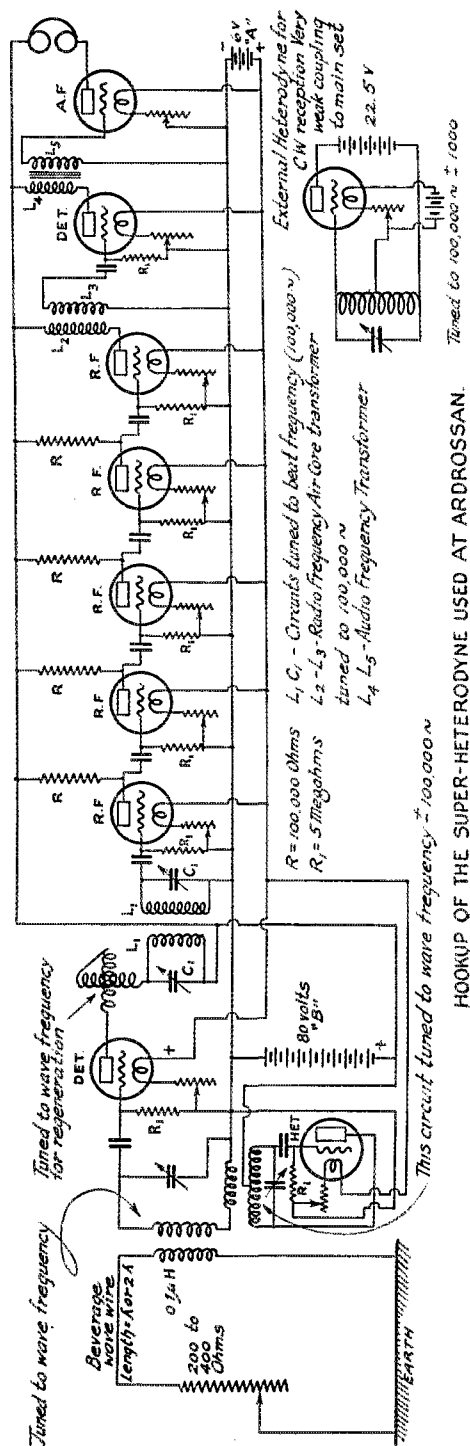

HOOKEUP OF THE SUPER-HETERODYNE USED AT ARDROSSAN.

was followed by general publicity which pretty thoroughly covered the British Isles.

The hospitality shown at Ardrossan could not have been excelled. Everyone seemed anxious to do all within their power to make things easier for us. We were invited on two or three occasions to visit the Murchie home, which was quite near to the scene of operations, but we never had the nerve to drag our muddy selves into anyone's home again.

During one afternoon a very amiable Scotch gentleman, along with other of the town's people visited the test station. This particular gentleman possessed the enviable ability to consume large quantities of Scotch liquor. He listened during a period of several minutes to various high power stations picked up, having been told in each case "That is Berlin", and "Here is New York", etc. At the conclusion of the demonstration his remarks ran something like this: "'Sall right, young man, y'understand I know a bit o'American swank when I see it."

Some real enjoyment unexpectedly included itself in our program on the next to the last night that we were in Ardrossan. Mr. Lee of the Eglinton Hotel proved himself a real friend by producing three of Scotland's fairest lassies who entertained us during one entire evening, with songs, music and dancing. All had very excellent voices, and I shall ever feel grateful toward those who provided this entertainment. It came at the psychological moment, and its effects, I am quite sure, were reflected in subsequent work.

On account of the excellent signals of Friday, Saturday and Sunday nights, violent efforts were made to get hold of a dictaphone in order that records might be taken of the transatlantic transmissions. These records would have opened the eyes of American amateurs, had it been possible to make them on any of the above-mentioned nights. On Sunday night in particular signals were exceptionally strong, there being times when they could have been read at least 300 feet from the tent, with rains falling and winds howling. Both Pearson and I at one time got up off our boxes, with the intention of going out to see how far we could hear the signals, but after having poked our heads through the flap in the tent we gave this up. The rain was coming down in torrents, so we satisfied ourselves with turning the receivers face down on the table and walking to extreme corners of the tent, carrying on conversations in loud voices, and reading the signals just the same.

Through error in coding, the first station heard, 1AAW, was broadcasted as being 1AAY. A cable was received to the effect that 1AAY was a spark coil station and that the transmitter was not in operation. Immediate correction was sent by

cable to the effect that 1AAW, not 1AAY was heard.

On reaching London, it was possible for me to go over two or three of the logs which had been handed in by British amateurs to Mr. Coursey. From these logs, and from what additional information Coursey had, it was apparent that the following stations had been heard by British amateurs: 2ZL, 1DA, 2BML, 2FP, 1AFV, 1UN, 1XM, 2ZC, and 1BCG. 1BCG was also heard in Holland, and I understand that it is reported that this station has also been copied on board ship, while the ship was at anchor in the harbor at Hamburg, Germany. A postscript on one of Mr. Coursey's letters, received during the course of the test, read as follows: "1BCG seems to be the star turn! ——— Kilowatts?"

The Holland station copied No. 1 from 1BCG complete, with the exception of the first word in the text. He was using a regenerative receiver of the American pattern, together with two stages of audio-frequency amplification. British stations were using radio-frequency amplification, and one amateur had 18 tubes in operation.

On reaching London, I had only a few hours, which I had hoped to spend in looking around, providing the fog had lifted. The fog had lifted, but I found that it would be impossible for me to pass through London without giving Coursey a complete story on the test, and to this end I spent about ten hours in his office dictating. What time was left was spent in rushing around saying good-byes to those whom I could reach, and I shall always regret that it was impossible for me to reach everyone.

The return trip on the Olympic was rather an uneventful one, except for the reception of a radiogram dated Hartford, Conn., requesting information as to date of arrival and also advising me that a reception committee would be on hand at the dock.

In due time I found myself emerging from the side of the huge ship, and fell into the arms of press correspondents, photographers and friends. Needless to say, everything was confusion, and it was with considerable relief that I presently found myself at lunch in the Pennsylvania Hotel, recounting amusing incidents to these more than welcome American "hams".

We have just finished making a real bit of radio history. What we have done means, first of all, that it now lies within our power to communicate frequently with our British cousins, provided we show the will to do so. I feel quite certain that there will be every inclination on the part of the British to co-operate to this end. I strongly urge upon those men whose transmitters showed up so well during these

(Concluded on page 46)

over the Rockies. It is reported that 4CB uses ten watts of CW. Mr. Wood's name has been recommended for consideration as manager of this division and since we are looking for a good man the T.M. requests further information from Mr. Wood. We can find places for several good live amateurs. Mr. Anderson has done much towards a Vancouver Division, but has his own to look after and still more and we would like to have a man on the ground.

PACIFIC DIVISION

J. V. Wise, Mgr.

Radio activity in this division is partly covered in this first report of the new Division Manager. At this early date it is rather a difficult proposition to gather more than a mere glimpse of what we are doing. Mr. H. L. Gooding, of Douglas, Ariz., has been appointed Superintendent of Arizona which is known as District A. District B includes the counties of San Diego, Orange, Imperial, and San Bernadino in California, of which Mr. J. F. Gray of Del Mar is Superintendent. District C under Mr. B. H. Dennis of San Fernando, Calif., has not been outlined as yet. Next month the complete outline will be given of those districts not mentioned here.

Stations north of Los Angeles who are heard handling relay traffic every night are 6AS, 6EX, 6HC, and 6HP. In the Sacramento and San Joaquin Valleys we find traffic being moved by the following stations: 6AK, 6KM, 6GF, 6FH, and 6ZX, with 6AFV and 6LU further north. In the vicinity of Fresno we find 6ALE on CW and 6ZU on spark always ready to QSR. A number of excellent stations in San Francisco and down the coast have not been heard from, but we will have more details in the next report.

6QR is about the only station in Nevada at this writing who is heard consistently. 6ZZ in Douglas, Ariz., continues to bat them out on both spark and CW.

Stations in and around San Diego are continually hampered in relay work by the mush from NPL, altho there are dozens doing the best they can through it. 6AJH had the misfortune, after he had climbed to the top of his mast, to fall with it, resulting in serious injury. 6AJH will be missed while he is recuperating.

Los Angeles will have a complete report next month. Come on, all of you. Let's show them that West Coast Amateurs in the Pacific Division are on the job.

OFFICIAL RECEPTION REPORT

(Concluded from page 40)

tests, to arrange for additional tests in conjunction with British amateurs, and as far as I am able to learn it will be possible

at no distant date for British amateurs to transmit on 180 meters, signals which should have a good chance of reaching this side.

The part which British amateurs have played in the tests just completed has accomplished far more in the way of the creation of enthusiasm for this sort of thing than anything else could possibly have accomplished. It has been pointed out to them that American amateurs—all stations—are transmitting every night, day in and day out, and that what the British heard during the week of the test, they may hear again and again throughout the coming season, provided they listen with sufficient patience,—and, what is most significant, that some of the stations heard from in America were using an output of but 30 watts.

It is quite a common thing to read in the British daily papers of such, to them, unusual procedures as the broadcasting by radio-telephony of "The Evening Hour Story for Children by the Man in the Moon," or "A Wireless Church with an audience of 20,000 to 30,000 people," or "Grand operas which are available to any who care to listen."

Is it hopeless to expect that sooner or later Europe will follow with similar programs? Would it not be foolish to presume that Europe can much longer remain blind to the advantages of such programs?

At any rate, American amateurs are watching the progress of our British contemporaries with an interest which is far more real than it has ever been in the past. British amateurs have proven their mettle and there are a great many of them now ready to be welcomed into the great order of the "Hard-Boiled Ham."

ANOTHER TRANSATLANTIC

As we go to press word reaches us that F. Clifford Estey's station at Salem, Mass., 1AFV, described in January QST, succeeded in the second week of January in passing three messages in a row to W. W. Burnham at London, Mr. Burnham acknowledging them by cable.

Already our Transatlantic Tests are bearing fruit. Let us hope that very soon Transatlantic Traffic Schedules can be established.